

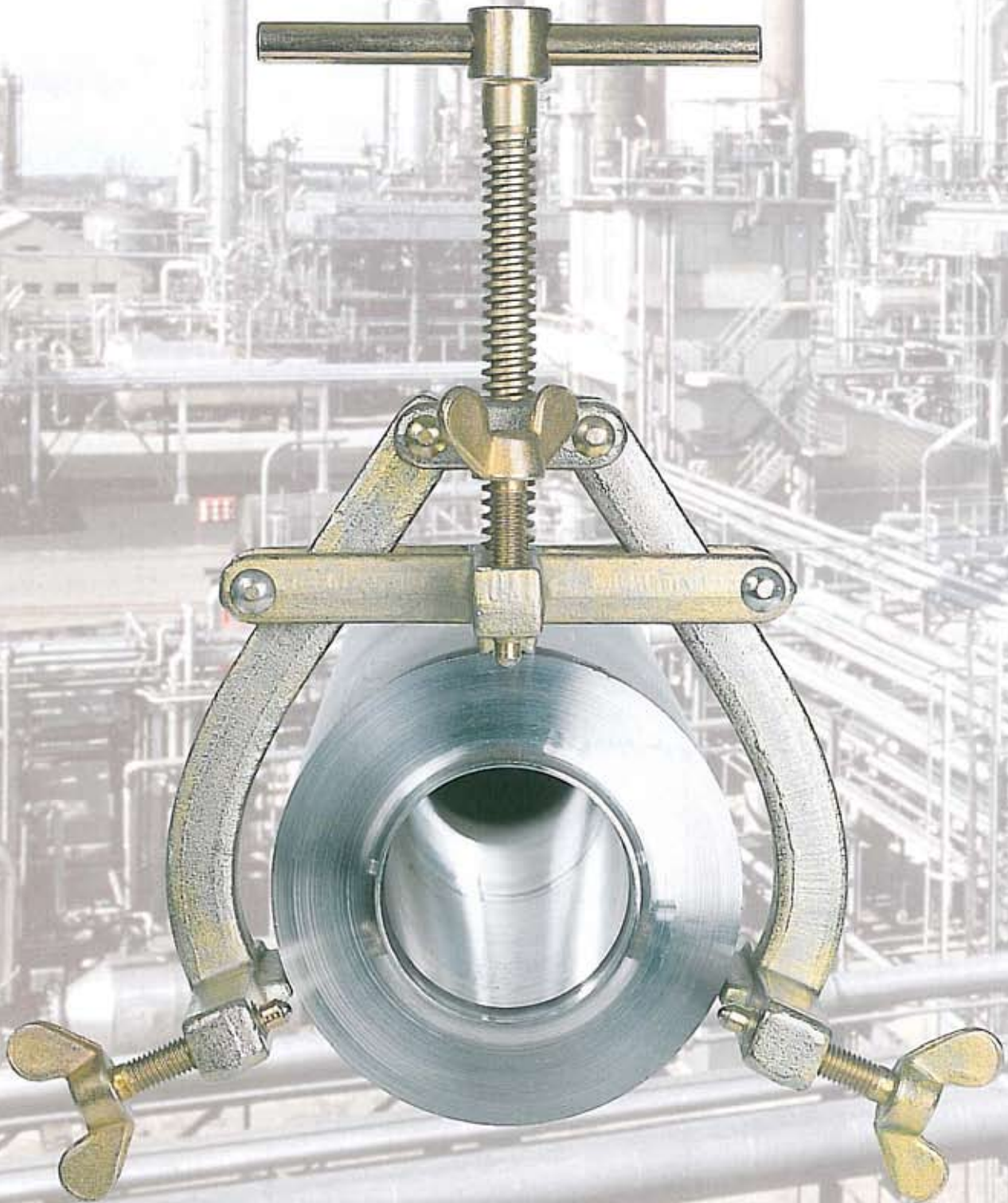

RÝCHLOUPÍNACIE CENTROVAČE





◀ Príruba - potrubie

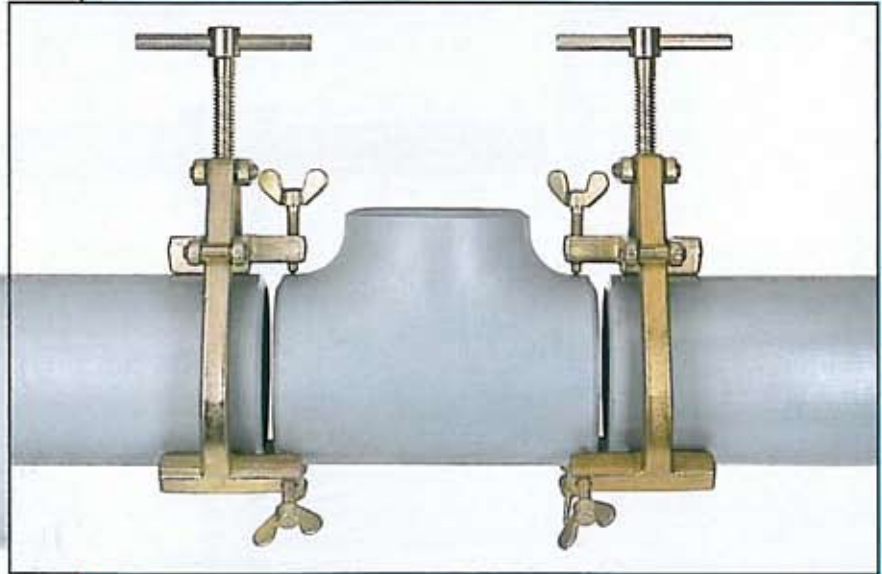
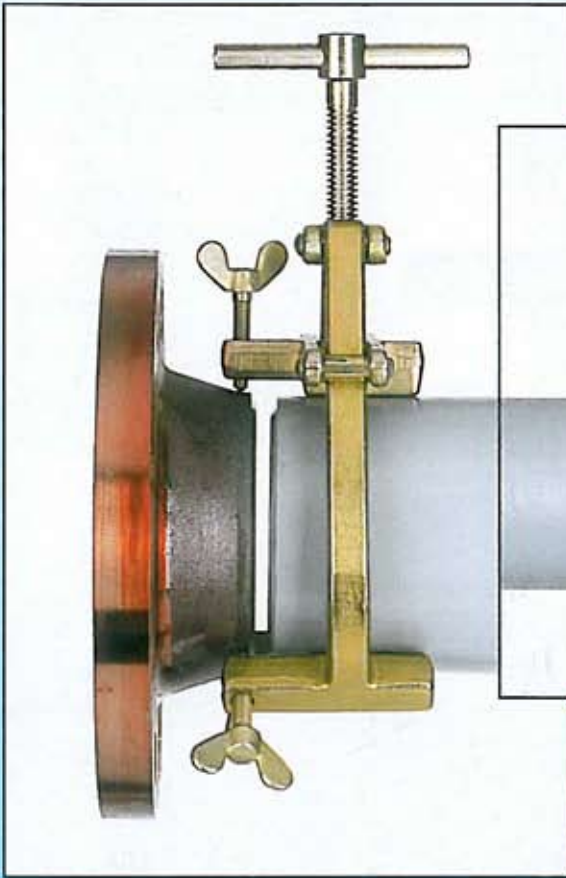

▲
Potrubie - T - potrubie

▼
Potrubie - T - potrubie - koleno

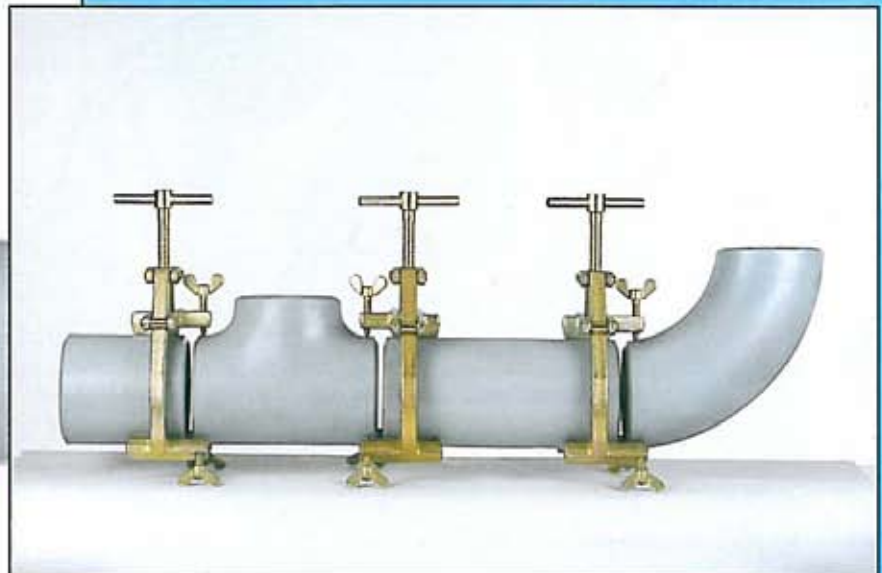
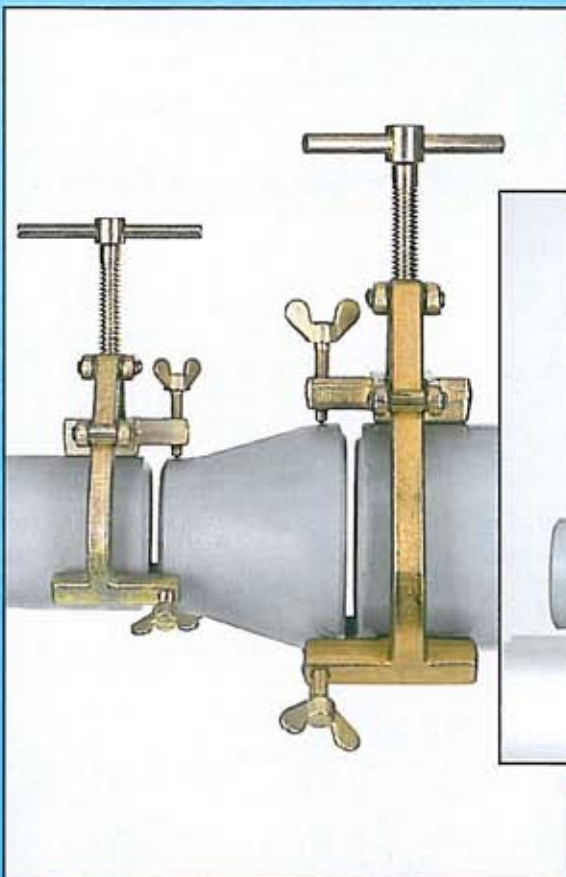

◀ Potrubie - redukcia - potrubie



Potrubie - potrubie ▶



▲ Potrubie - T s držiakom

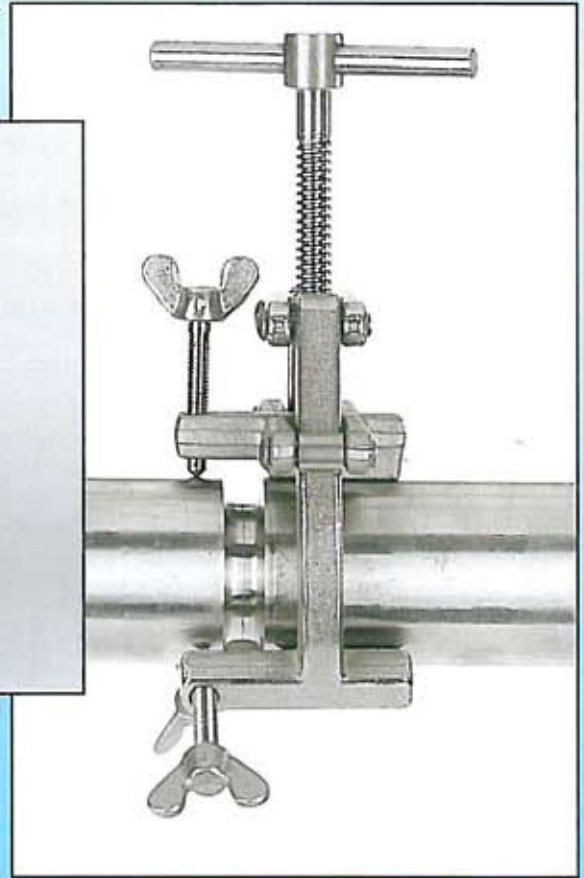

Príruba - koleno s držiakom

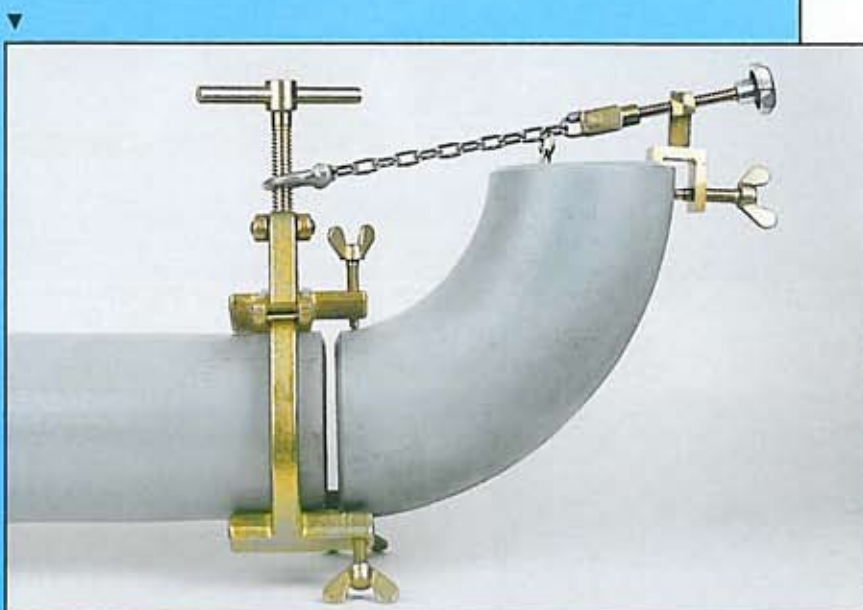

Potrubie - potrubie ▶

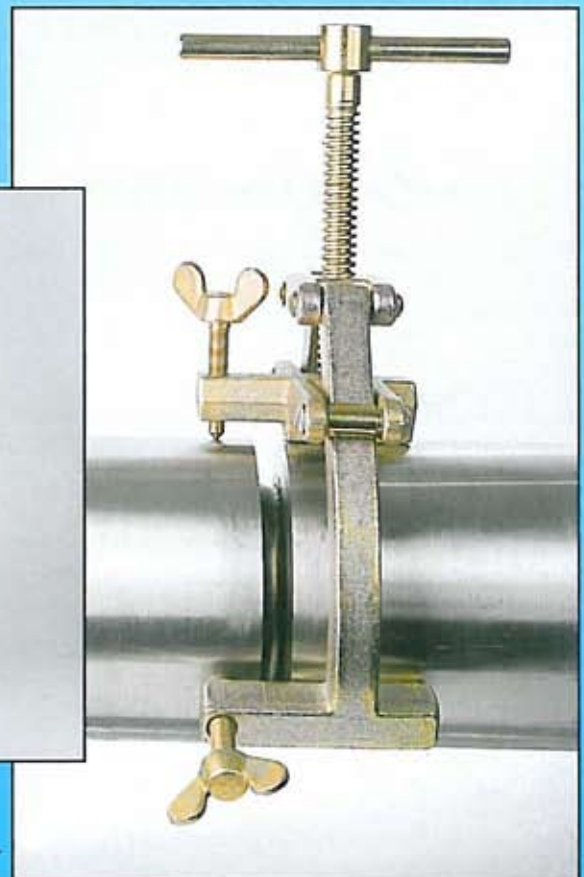



- Efektívna príprava zvaru.
- Jednoduché a rýchle upnutie a ustavenie potrubia.
- Zaistenie maximálnej bezpečnosti pri práci.
- Vysoká kvalita výsledného zvaru vďaka vysokej precízности ustavenia.
- Všetky prvky sú vyrobené z galvanicky pokovovaných ocelových výkovkov alebo z nerezovej ocele.
- Krídlové matice z nerez.
- Patentovaná technológia.

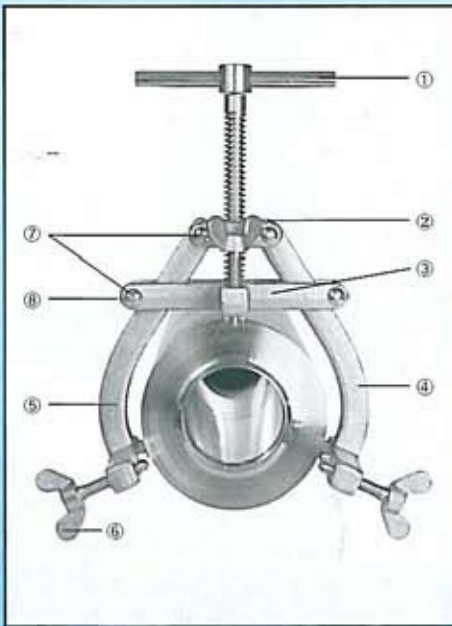

1. Doťahovacia skrutka
2. H-svorka
3. Spojka
4. Rameno (pravé)
5. Rameno (ľavé)
6. Krídlová matica
7. Nit
8. Klzná kladka



Typ/Type	JA 1-3"	JA 2-5"	JA 4-7"	JA 5-9"	JA 10-14"
Pre Ø potrubia:	20-90 mm 1-3"	50-150 mm 2-5"	90-190 mm 4-7"	125-225 mm 5-9"	225 - 370 mm 10-14"
Hmotnosť:	1,3 kg	3,0 kg	3,3 kg	7,0 kg	9,0 kg



VAW Welding, s.r.o.

Hlavná 3
038 52 Sučany
Tel.: 043/400 34 30
Fax: 043/400 34 31
<http://www.vaw.sk>
e-mail: vaw@vaw.sk